

Monitors

50mm Portable Ensign Monitor



SAFETY INDUSTRIES

Pty Limited

Description

The Ensign Model 2030 50mm portable monitor is a stainless steel monitor with friction swivel locks. The monitor can be used with Orion Model 3000, A-40 or A-50 nozzles and Orion Foam Lord model FLD2-50 nozzles. It is not recommended that aspirating foam nozzles be used with these monitors.

Specifications

Maximum Flow:	1500 lpm
Horizontal Rotation:	270°
Vertical Movement:	+30° to +90°
Inlet Connection	50mm BSP M
Outlet Connection	40mm BSP M

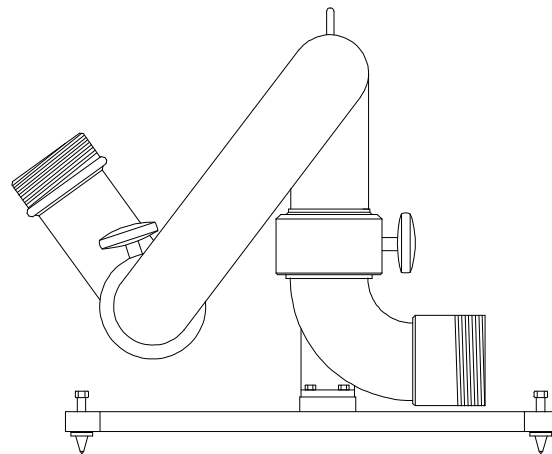
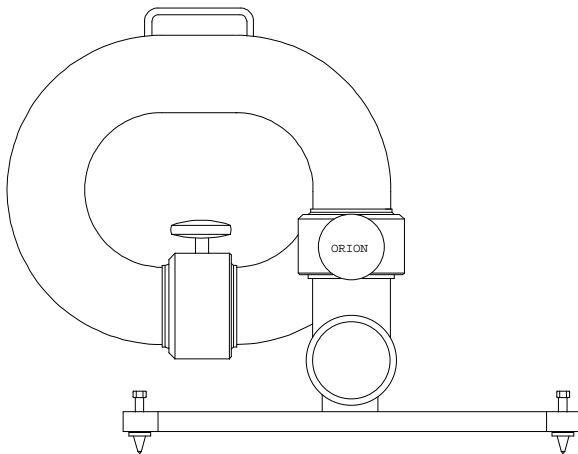

Materials of Construction

Waterway:	316 Stainless Steel
Swivels:	316 Stainless Steel
Balls:	Delrin
Grease Nipples:	316 Stainless Steel
Locking Knob:	Aluminium
Handle:	316 Stainless Steel
Fasteners:	316 Stainless Steel
Base	Aluminium (Bronze optional)
Spikes	Hardened Steel

ORION SAFETY INDUSTRIES PTY LIMITED

A.C.N. 002 538 696

Tel (61) 2 9821 2244 29 SHEPHERD STREET LIVERPOOL NSW 2170 FAX (61) 2 9821 2906
AUSTRALIA

Performance Data

Friction Loss Curve

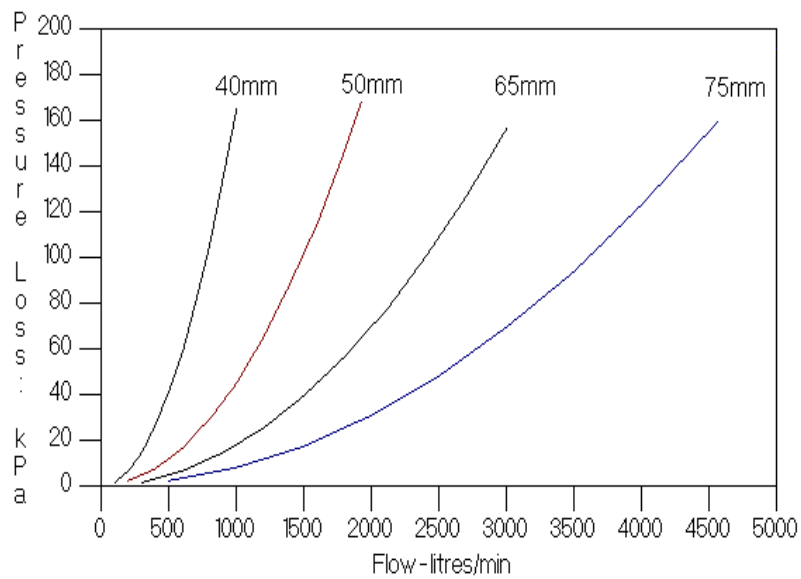

Options

Outlet Connection:

40mm BSP Male as Standard.

Inlet Connection:

Single 50mm BSP Male as standard. A range of hose couplings can be fitted.

ORION SAFETY INDUSTRIES PTY LIMITED

A.C.N. 002 538 696

Tel (61) 2 9821 2244 29 SHEPHERD STREET LIVERPOOL NSW 2170 FAX (61) 2 9821 2906
AUSTRALIA