

Monitors



SAFETY INDUSTRIES
Pty Limited

Electric Remote Controlled Ranger Monitor – Model EM-xxxTEN

Description

The Ranger Model EM-xxxTEN monitor designed for use in marine environments and hazardous areas. Construction materials are selected for seawater corrosion resistance. The monitor can be used with Orion fog nozzles, Foam Lord nozzles and with FF-Series aspirated foam nozzles.

The Ranger Model EM-xxxTEN uses Exd/e motors for movement control. The monitor is available with a variety of three (3) phase motors to suit the available power supply including 380, 415, 440 and 480 voltages. The standard motor is 0.18 kW for the 100mm and 150mm models and 0.37kW for the larger models though this may depend on the final motor selection for the project.



Each monitor requires a relay module (ECC Module) that controls monitor and nozzle movements and provides overload protection to the motors. The ECC Module requires some simple site wiring connections. The ECC module can be installed adjacent to the monitor in an EEXd enclosure or in the control panel. The location of the ECC module will depend on the installation cost. More cable is required if the ECC module is located in the control panel.

Specifications

Working Pressure:	1600 kPa
Hydrostatic Pressure Test:	2600 kPa
Inlet Flange:	ANSI 150#
Outlet:	Table E or ANSI 150# or Threaded
Swivel Bearings:	Plain Bearings.
Horizontal Rotation:	>355°
Vertical Movement:	+90° to -60°

ORION SAFETY INDUSTRIES PTY LIMITED

A.C.N. 002 538 696

Tel (61) 2 9821 2244 29 SHEPHERD STREET LIVERPOOL NSW 2170 FAX (61) 2 9821 2906
AUSTRALIA

Materials of Construction

Waterway:	316 Stainless Steel
Swivels:	Aluminium Bronze Alloy
Inlet Flange:	Aluminium Bronze Alloy – Flat Faced
Balls:	316 Stainless Steel
Grease Nipples:	316 Stainless Steel
Fasteners:	316 Stainless Steel

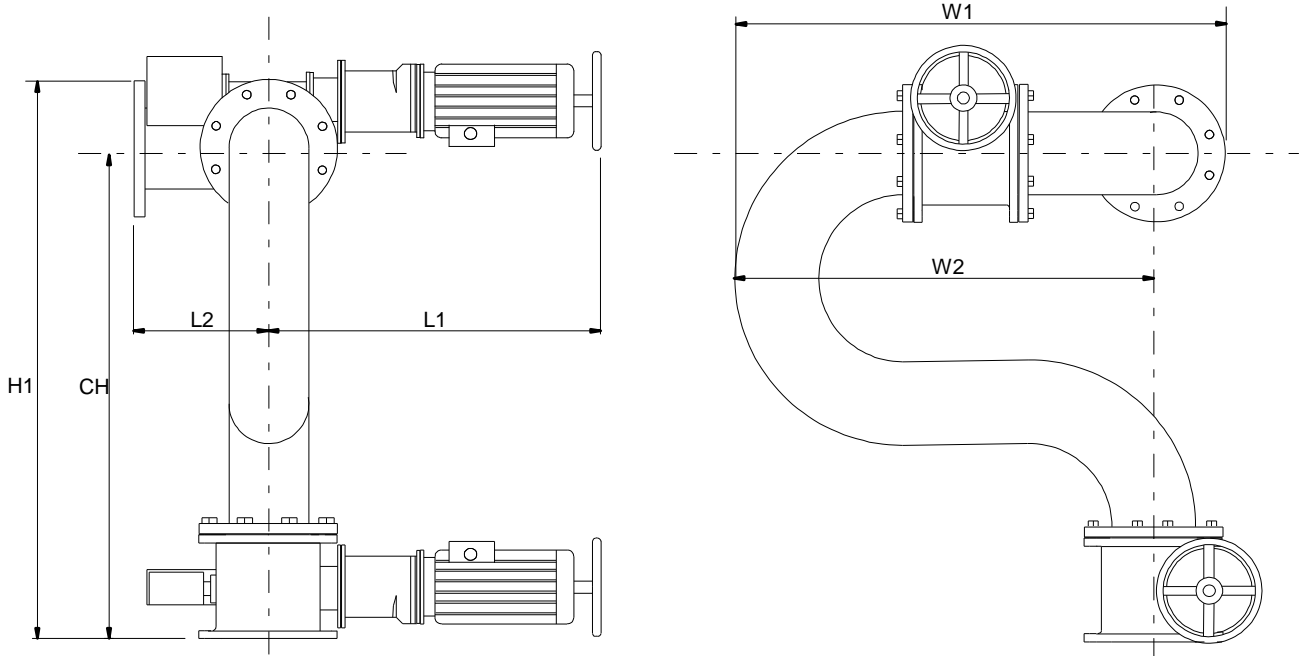

Dimensions

	EM-100	EM-150	EM-200	EM-250
W1	650 mm	880 mm	1180 mm	1395 mm
W2	540 mm	740 mm	1010 mm	1190 mm
H1	740 mm	1010 mm	1380 mm	1650 mm
CH	630 mm	870 mm	1210 mm	1445 mm
L1 *	570 mm	665 mm	695 mm	735 mm
L2 **	160 mm	235 mm	315 mm	390 mm

* This dimension depends on the gearbox & motor selection.

** This dimension depends on the outlet selection.

ORION SAFETY INDUSTRIES PTY LIMITED

A.C.N. 002 538 696

Tel (61) 2 9821 2244 29 SHEPHERD STREET LIVERPOOL NSW 2170 FAX (61) 2 9821 2906
AUSTRALIA

Performance Data

Friction Loss Curve

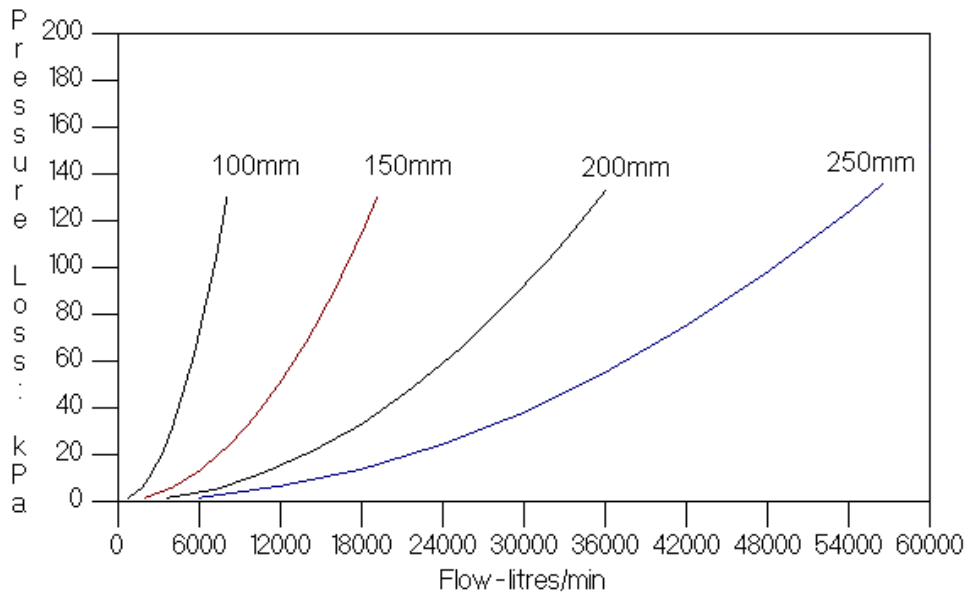

Options

- Outlet Connection: 80mm BSP Male as Standard, other configurations are available optional
Flanged outlets available also
- Inlet Flange: No other options but adaptor spools can be provided
- Controls:
- Panel mount joystick units
 - Handheld pendant controllers
 - Indoor, outdoor and EEXd control panels
 - Manual handwheel override
 - Position Indications systems
 - Radio remote control
 - RS-485 network control systems
 - Computer interfacing

Ranger Models

Model No:	EM-100	EM-150	EM-200	EM-250
Nominal Size:	100mm	150mm	200mm	250mm
Inlet Flange ANSI 150# Flat Face	100mm	150mm	200mm	250mm
Maximum Flow (lpm):	7,500	16,000	35,000	55,000

ORION SAFETY INDUSTRIES PTY LIMITED

A.C.N. 002 538 696

Tel (61) 2 9821 2244 29 SHEPHERD STREET LIVERPOOL NSW 2170 FAX (61) 2 9821 2906
AUSTRALIA