

Monitors

Hydraulic Remote Controlled Ranger Monitor – Model HM-XXXTN



SAFETY INDUSTRIES
Pty Limited

Description

The Ranger Model HM-XXXTN monitors are designed for use in marine environments and hazardous areas. Construction materials are selected for seawater corrosion resistance. These monitors can be used with Orion fog nozzles, Foam Lord nozzles and with FF-Series aspirated foam nozzles.

The Ranger Monitors uses hydraulic motors for movement control. Travel limiting may be achieved electrically or mechanically (standard).

Specifications

Maximum Working Pressure:	1600 kPa
Hydrostatic Pressure Test:	2600 kPa
Inlet Flange:	ANSI 150#
Outlet:	Table E or ANSI 150# or Threaded
Swivel Bearings:	Plain Bearings.
Horizontal Rotation:	>355°
Vertical Movement:	+90° to -60°

Materials of Construction

Waterway:	316 Stainless Steel
Swivels:	Aluminium Bronze Alloy
Inlet Flange:	Aluminium Bronze Alloy – Flat Faced
Balls:	316 Stainless Steel
Grease Nipples:	316 Stainless Steel
Fasteners:	316 Stainless Steel

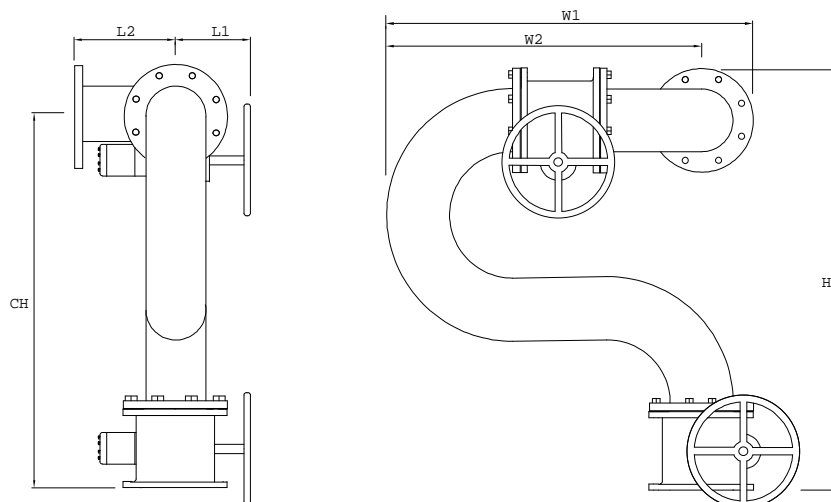

ORION SAFETY INDUSTRIES PTY LIMITED

A.C.N. 002 538 696

Tel (61) 2 9821 2244 29 SHEPHERD STREET LIVERPOOL NSW 2170 FAX (61) 2 9821 2906
AUSTRALIA

Dimensions

	HM-100	HM-150	HM-200	HM-250
W1	650 mm	880 mm	1180 mm	1395 mm
W2	540 mm	740 mm	1010 mm	1190 mm
H1	888 mm	1010 mm	1380 mm	1650 mm
CH	780 mm	870 mm	1210 mm	1445 mm
L1	255 mm	300 mm	330 mm	370 mm
L2	160 mm	235 mm	315 mm	390 mm

Performance Data

Friction Loss Curve

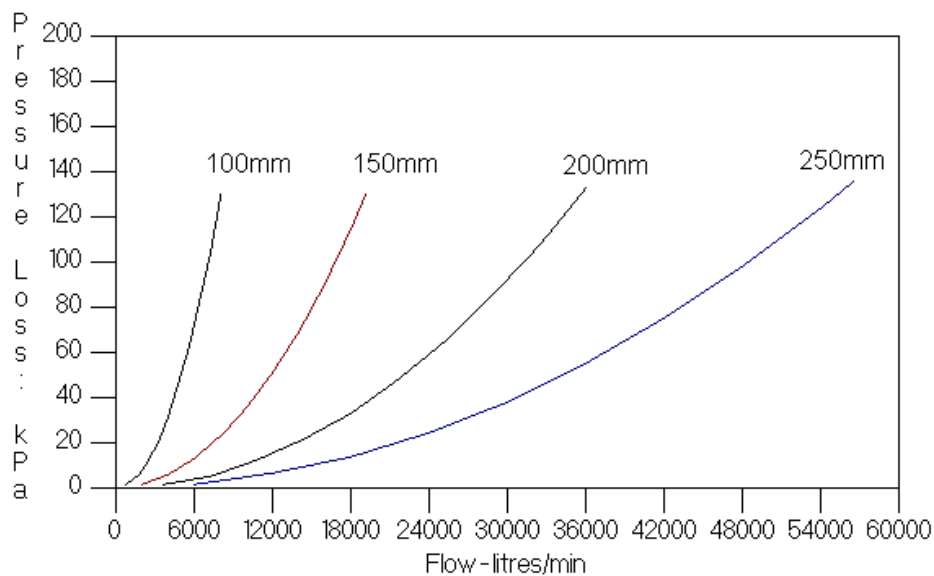

Options

Controls:

- Panel mount joystick units
- Handheld pendant controllers
- Indoor, outdoor and EEXd control panels
- Manual handwheel override
- Hydraulic power units in electric or water powered, for hazardous and non-hazardous areas
- Valve modules for hazardous areas

Ranger Models

Model No:	HM-100	HM-150	HM-200	HM-250
Nominal Size:	100mm	150mm	200mm	250mm
Inlet Flange ANSI 150# Flat Face	100mm	150mm	200mm	250mm
Maximum Flow (lpm):	7,500	16,000	35,000	60,000

ORION SAFETY INDUSTRIES PTY LIMITED

A.C.N. 002 538 696

Tel (61) 2 9821 2244 29 SHEPHERD STREET LIVERPOOL NSW 2170 FAX (61) 2 9821 2906 AUSTRALIA