

Monitors

50mm Manual Sentinel Monitor



SAFETY INDUSTRIES
Pty Limited



Description

The Sentinel 50mm manual monitor is an stainless steel monitor with friction swivel locks. The monitor can be used with Orion Model A-40, A-50 and NP250-40 fog nozzles. It is not recommended that aspirating foam nozzles be used with these monitors.

Specifications

Maximum Flow:	1500
Horizontal Rotation:	360°
Vertical Movement:	150°
Inlet Connection	50mm Table'E" Flange
Outlet Connection	40mm BSP Male

Materials of Construction

Waterway:	316 Stainless Steel
Balls:	Delrin
Grease Nipples:	316 Stainless Steel
Locking Knobs:	Aluminium
Handle:	316 Stainless Steel
Fasteners:	316 Stainless Steel
Inlet Flange:	50mm Table E as standard. Other sizes and flange types are available.

ORION SAFETY INDUSTRIES PTY LIMITED

A.C.N. 002 538 696

Tel (61) 2 9821 2244 29 SHEPHERD STREET LIVERPOOL NSW 2170 FAX (61) 2 9821 2906
AUSTRALIA

Performance Data

Friction Loss Curve

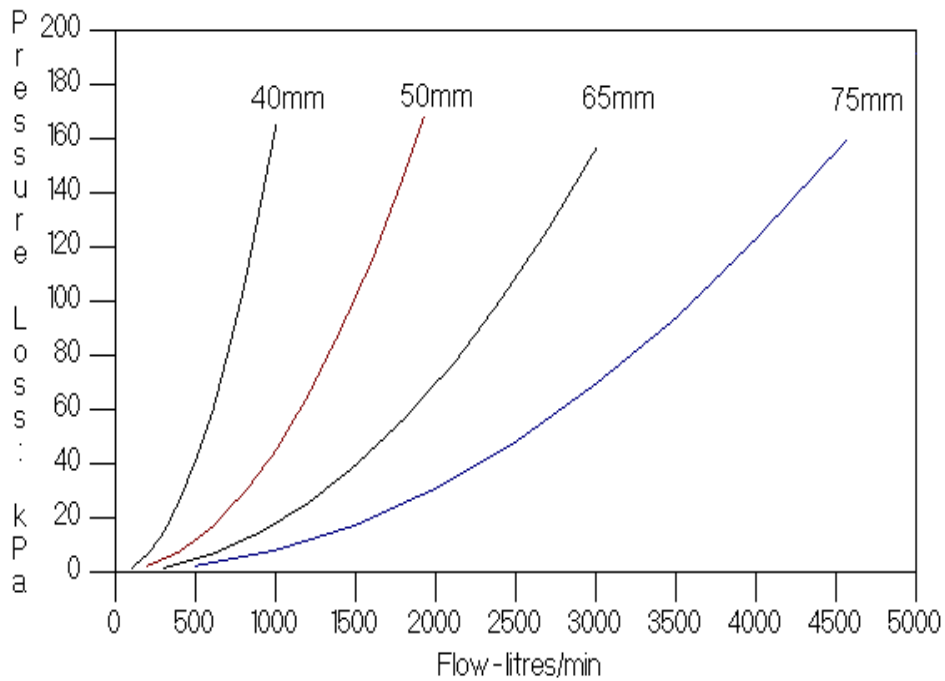

Options

Outlet Connection: 40mm BSP Male as Standard, 50mm BSP Male optional.

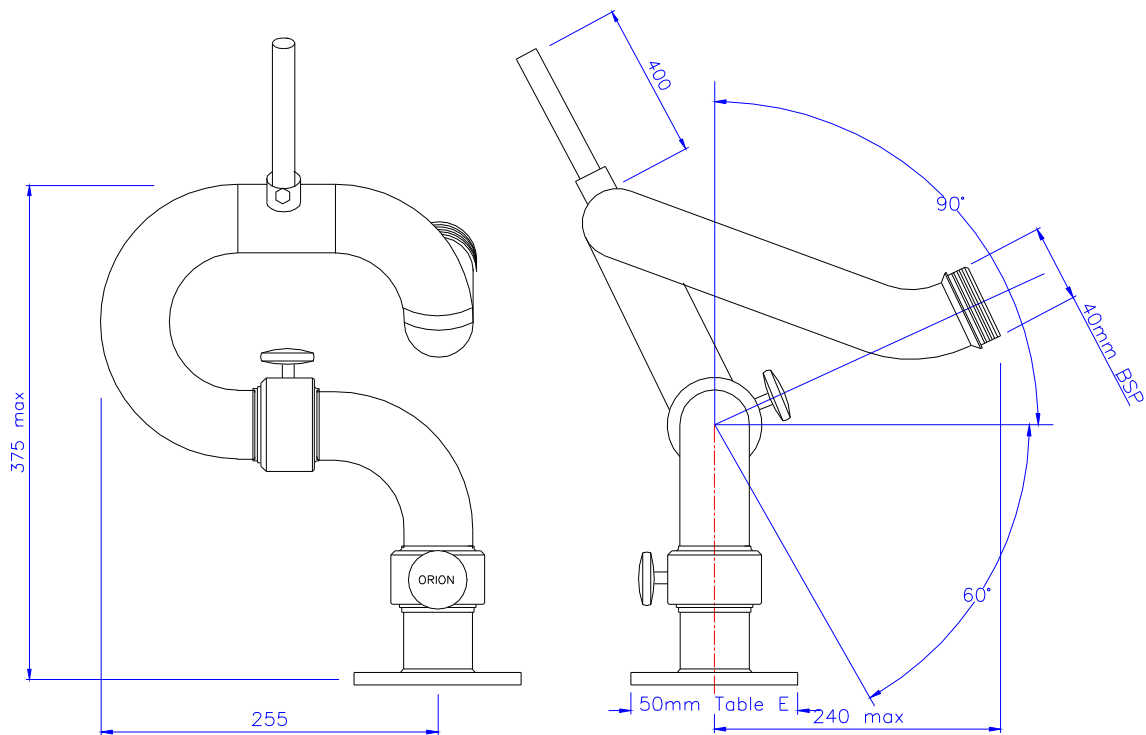

ORION SAFETY INDUSTRIES PTY LIMITED

A.C.N. 002 538 696

Tel (61) 2 9821 2244 29 SHEPHERD STREET LIVERPOOL NSW 2170 FAX (61) 2 9821 2906 AUSTRALIA